

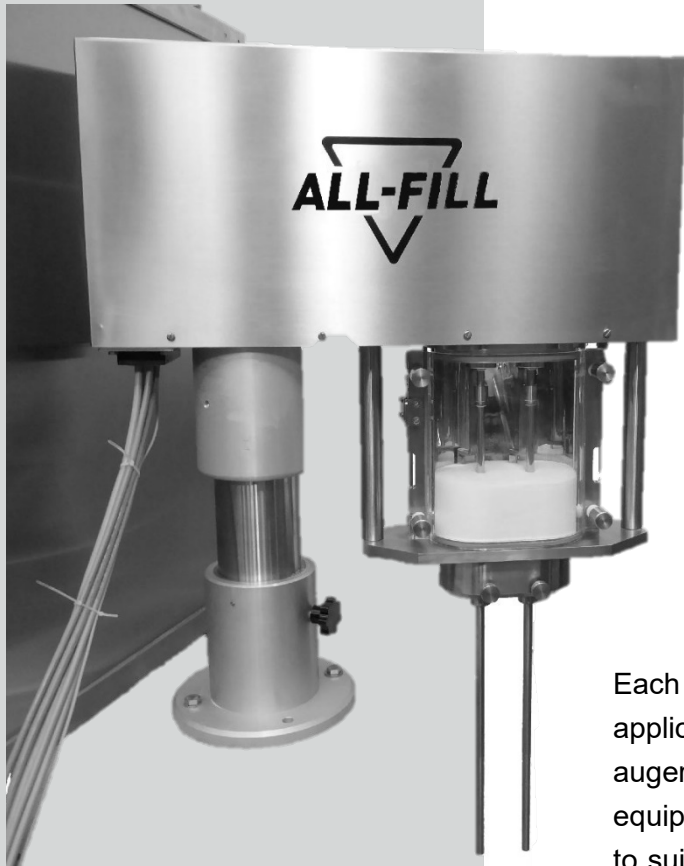

Series Multi-Fill Multiple Auger Filling Systems

All-Fill “Multi-Fill” filling systems provide fast, accurate, multi-position dispensing of powders and viscous products when used in conjunction with:

- ▼ Vertical Form-Fill-Seal machines
- ▼ Horizontal Thermo-formers
- ▼ Stick-Pack machines
- ▼ Horizontal Vacuum Forming machines
- ▼ Pouch Makers
- ▼ Multiple Lane Indexing machines



In fact, the Multi-Fill machine is suited to any application where a precise amount of product needs to be deposited at two or more positions simultaneously. Each system consists of multiple, individually controlled servo-driven augers, variable speed agitation for each auger, common product hopper and control system to separately control dispensing at each fill position.

Each Multi-Fill system is purpose-designed to suit the individual application. The number of augers, centre distance between augers, funnel length, overall height etc. are matched to the host equipment. Tooling (auger, funnel, agitation blade) is designed to suit the powders to be filled, the output and accuracy levels required.

Standard Features

- ▼ 2-20 filling nozzles
- ▼ All stainless-steel contact parts
- ▼ Common gasketed stainless steel hopper
- ▼ No-tools removable change parts
- ▼ Augers machined from solid
- ▼ Independent servo-driven augers
- ▼ Independent agitation drive
- ▼ PLC control via touch-screen panel

Options

- ▼ “Easi-View” transparent hopper wall
- ▼ Compartmentalised hoppers
- ▼ Hopper Level Probe
- ▼ Bulk Feed Accessories
- ▼ Motorised jacking system
- ▼ Fill Weight Feedback from external Checkweigher
- ▼ Full stainless-steel specification
- ▼ 316L contact parts

All-Fill International Ltd

Unit 5 Gateshead Close | Sunderland Road | Sandy | Bedfordshire | SG19 1RS | United Kingdom

+44(0)1767 691100

info@allfill.co.uk

www.allfill.co.uk

Series Multi-Fill

Mounting Options

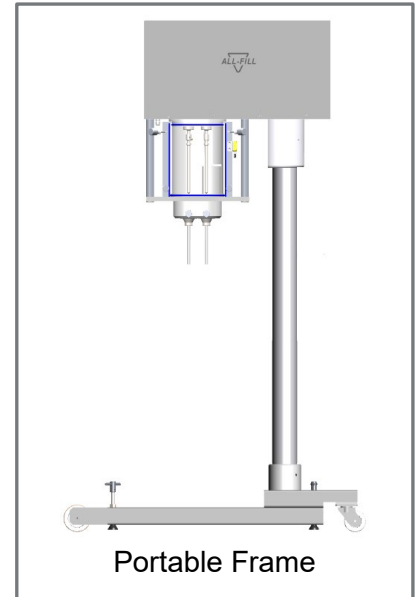
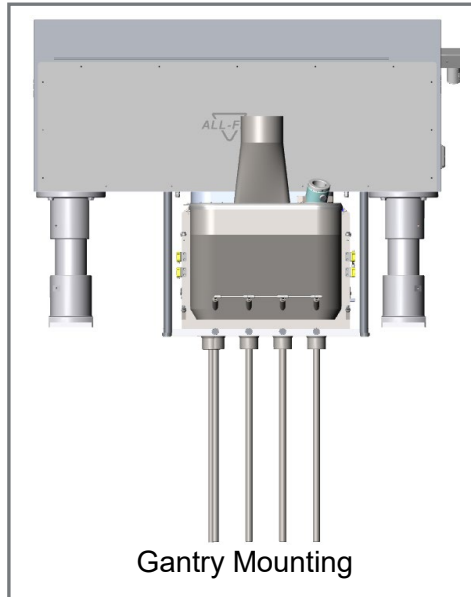
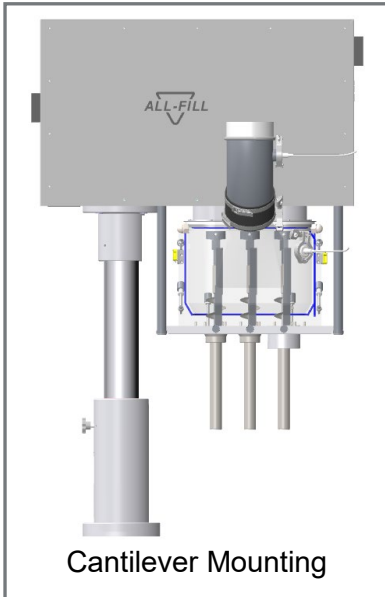

Standard Specification

Controller type:	Siemens PLC	Auger Motor:	Servo
HMI:	Colour touch-screen panel	Auger revs:	0.0003 rev incremental adjustment
Agitation options:	Continuous	Auger tooling:	Manufactured from solid steel
	With fill only	Contact parts:	304 grade stainless steel
	With fill and time delay	Fill weight range:	20mg – 50kg
	No agitation		



Series Multi-Fill

Mounted over a three-lane indexing rotary machine

Acrylic hopper

110mm auger centres

HMI position in client's electrical cabinet

Three sets of Free-Flow tooling to suit different fill weights

All-Fill International Ltd

Unit 5 Gateshead Close | Sunderland Road | Sandy | Bedfordshire | SG19 1RS | United Kingdom

+44(0)1767 691100

info@allfill.co.uk

www.allfill.co.uk